

## PNA - Conical Screw Mixer

### Introduction:



The PerMix PNA series Conical Screw Mixer is a batch mixing equipment used widely in applications that require gentle mixing and minimal heat generation without any product distortion. Because no seals or bearings are exposed in product zone, there is no risk of lubricant contamination.

The PerMix PNA series Conical Screw Mixers is featured by its very low energy consumption, low maintenance cost, but high performance of mixing.

### Features & Advantages:

- No minimum volume required
- Complete discharge of materials
- Easy cleaning of the machine
- Gentle mixing for fragile and friction sensitive materials
- Free of cross contamination with shaft sealing above the product

## How It Works:

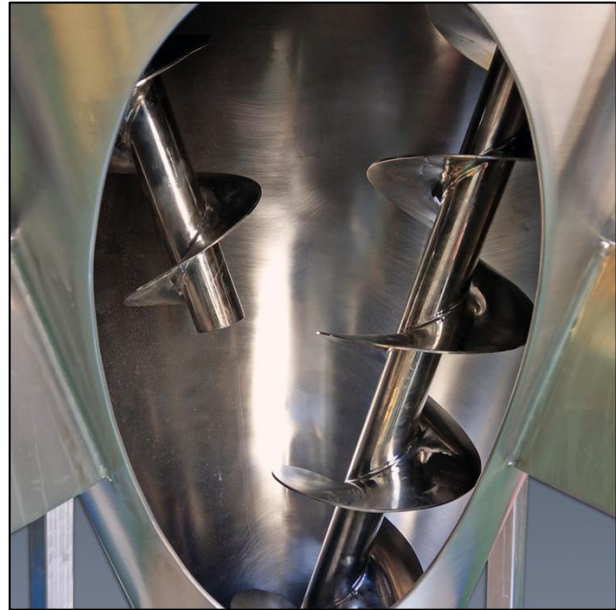
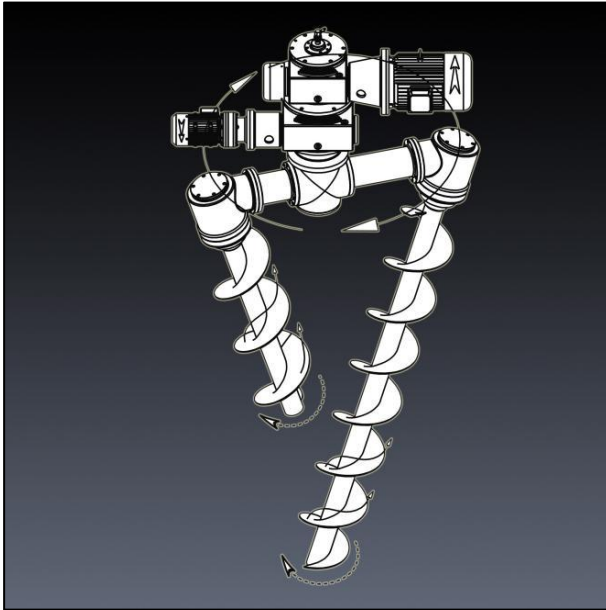

A spiral screw (or two, three screws according to specified application) inside of a PerMix PNA series Conical Screw Mixer rotates by its own axle parallel and near the wall of the cone vessel. It lifts the powders around it from bottom to the top, and then the powder falls down due to the gravity. At the same time, the spiral screw rotates around the center of the cone like a planetary, so that the powders in every corner of the cone can be mixed by the screw.

## Options:

### - Feeding & Discharging



A variety of feeding & discharging methods available.

### - Screw Type

We offer single screw, double screw and triple screw to give different mixing intensity.

**- Drive system**

Drive system by geared motor, cycloidal reducer, worm reducer, belt or chain transmission, etc.

**- Construction Material and Finish**

We are able to offer our PVR Mixers with contact part to be built in Carbon steel, SS304, SS316/316L, Titanium, Duplex stainless steel, Hastelloy, etc. Finish of internal and external finish can be dull polished, 180 grit polished (food grade), or mirror polished. For abrasive materials we offer hardened steel as the contact part.

**- Heating/Cooling jacket**

Jacketed trough for heating/cooling operation

**- Vacuum drying & deaerating**



The PNA mixer can be designed for vacuum drying & deaerating or for inner pressure working for special applications.

**- Spray nozzle**

Liquid can be added into the powder by spray nozzles on the top.

## Specifications:

Model	Total volume (liter)	Working volume (liter)	Power (*) (kW)	RPM	Dia. (mm)	H, total height (**) (mm)	Inlet (***) (mm)	Outlet (****) (mm)	Weight (kg)
PNA-200	200	120	2.2+0.37	140/2	888	1557	140	230	500
PNA-300	300	180	2.2+0.37	140/2	990	1722	180	230	550
PNA-500	500	300	3+0.55	140/2	1156	1991	200	230	600
PNA-800	800	480	4+0.55	60/2	1492	2256	250	300	950
PNA-1000	1000	600	4+0.55	60/2	1600	2432	300	300	1200
PNA-1500	1500	900	5.5+0.75	60/2	1780	2725	300	300	1350
PNA-2000	2000	1200	5.5+0.75	60/2	1948	3001	350	350	1500
PNA-2500	2500	1500	7.5+1.5	60/2	2062	3024	350	350	1800
PNA-3000	3000	1800	7.5+1.5	60/2	2175	3207	350	350	2100
PNA-4000	4000	2400	11+2.2	40/2	2435	4010	400	400	2500
PNA-5000	5000	3000	15+2.2	40/2	2578	4260	400	400	3000
PNA-6000	6000	3600	18.5+3	40/2	2715	4470	400	400	3500
PNA-8000	8000	4800	22+3	40/1.3	2792	5000	400	450	3800
PNA-10000	10000	6000	30+4	40/1.3	3000	5240	500	450	4300

1. (\*) (\*\*) (\*\*\*) (\*\*\*\*): Changes are available according to the customer's request.
2. Customized sizes available as per request
3. All specifications and illustrations are as accurate as is reasonably possible, but they are not binding.
4. PerMix reserves the right to modify the design without notice.

**Gallery:**



**PNA Mixer with Pneumatic Discharge**

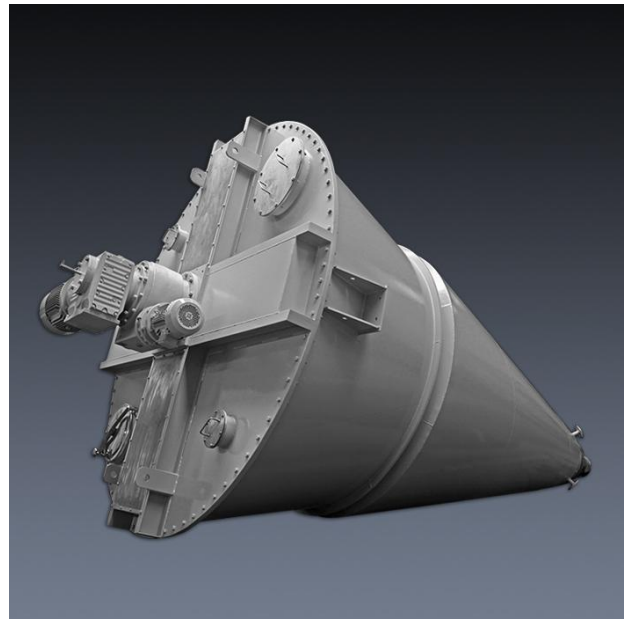

**PNA Conical Screw Mixer with Heating Jacket**



**PNA-300 Conical Screw Mixer**



**Conical Screw Mixers Installed with Platform**