

PRB - Ribbon Mixer

Introduction:



PerMix PRB series Ribbon Mixer is an efficient and versatile blending machine for mixing of dry powders, granules and viscous pastes homogeneously. It is able to give a satisfying "homogeneity grade" for mixing jobs due to the special design of a mixing agitator with dual ribbons inside of a U-shaped working trough.

PerMix designs our PRB Ribbon Blenders which are able to achieve a maximum "mixing ratio" of 1:500,000, which means you can get the desired mixture proportion of components in as small as 1 gram with a batch of 500kg.

How It Works:

PerMix PRB Ribbon Mixer consists of one electrical motor, one gearbox, and a shaft with double ribbons located in a U-shaped vessel. The external & inner ribbons are designed in such a way that the powder materials are pushed to move from center to the two ends of vessel, and meanwhile from ends to the center; besides, the powder materials are lifted up along the ribbon edges but then drop

due to gravity. In such a three-dimensional way, the total powder can be mixed fast in the vessel. It asks for a short mixing time and relatively low power consumption.



The shaft is sealed with stuffing box with multiple PTFE packings (sometimes with a lantern ring for air purge) at both ends. Materials are loaded from top side, and a flush fitting discharge valve is located at the bottom side in the center. The discharge height can be adjusted as per requirement, so that material gets discharged into the container below it without floating dust.

Special Design of Motorized Tilting:



PerMix has designed a special feature for food application (salad mixing) with motorized tilting for discharge. The machine is built in full stainless steel construction for wash cleaning, a top lid with counterweight for easy manual opening.

Optional Features:



- Ribbon (3 types available)

We offer different types of mixing ribbon for different applications. Standard ribbon is used to provide general blending purpose, with center discharge; Interrupted ribbon is applied for viscous material; Continuous ribbon is used for continuous operation with one side feeding and the other side discharging.

- Construction material

We are able to offer Ribbon Mixers with contact part to be built by Carbon steel, SS304, SS316/316L, Titanium, Duplex stainless steel, Hastelloy, etc. For abrasive materials we offer hardened steel as the contact part. Also we produce Ribbon Mixers all by stainless steel in order to meet the high hygienic requirement.

- Drive system

Drive system by geared motor, cycloidal reducer, worm reducer, belt or chain transmission, etc.

- Heating/Cooling jacket

Jacketed trough for heating/cooling operation

- Spray nozzle

Liquid can be added into the powder by spray nozzles on the top.

- Continuous operation

We can supply machines for continuous work when a large capacity per hour is needed for the same material.

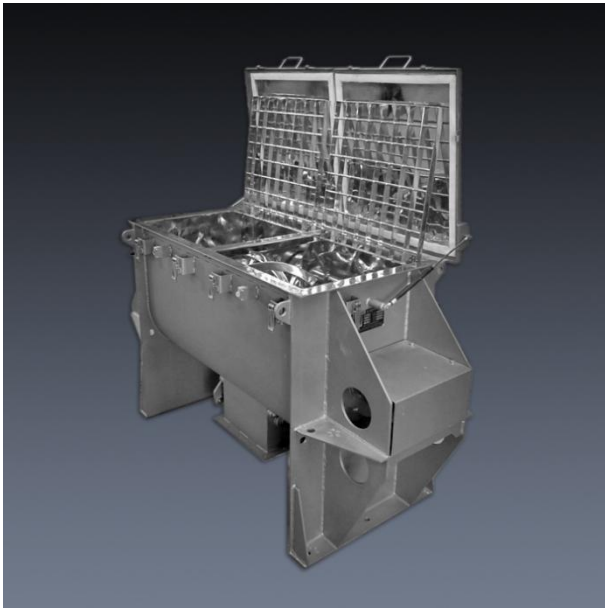

- Customized feeding & discharging

A variety of feeding & discharging methods can be selected by the customers. For feeding of materials, bag dump station can be mounted on the top of the U-shaped trough. Safety grid can be installed to prevent the possible injury to the worker. For discharge of the products, manual, pneumatic, or motorized operated valves can be selected according to the customers' preference. They are prepared to fit into any existing production line easily.

- Vacuum drying & deaerating

The mixer can be designed for vacuum drying & deaerating for special applications.



- Extended height bases

Height of our Ribbon Mixer can be defined according to customer' s condition.

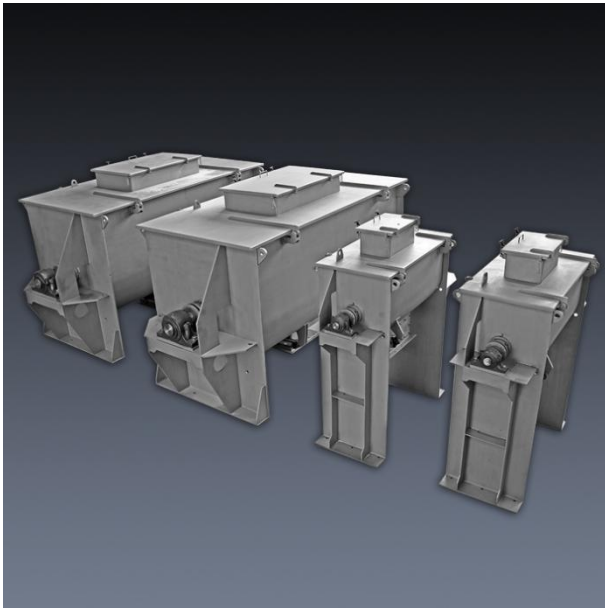

- External body by bead blasted finish

For full stainless steel mixers, external parts can be bead blasted.

Specifications:

Model	Total capacity (liter)	Useful capacity (liter)	Power (*) (kW)	RPM	L (mm)	W (mm)	H (mm)	Outlet (**)	Weight (kg)
PRB-100	100	40-60	2.2	80	1,250	840	613	80x80	250
PRB-300	300	120-180	4	72	1,630	1,005	1,015	250x80	600
PRB-500	500	200-300	5.5	65	2,030	1,175	1,140	360x120	850
PRB-1000	1,000	400-600	11	50	2,460	1,455	1,375	360x120	1,300
PRB-2000	2,000	800-1,200	18.5	38	3,050	1,710	1,545	360x120	2,300
PRB-3000	3,000	1,200-1,800	22	35	3,500	1,865	1,680	360x120	3,300
PRB-4000	4,000	1,600-2,400	22	35	3,870	1,985	1,821	500x120	3,600
PRB-5000	5,000	2,000-3,000	30	30	4,090	2,062	1,945	500x120	4,620
PRB-6000	6,000	2,400-3,600	37	27	4,250	1,802	2,380	500x120	5,300
PRB-8000	8,000	3,200-4,800	45	24	4,590	1,956	2,504	700x120	6,800
PRB-10000	10,000	4,000-6,000	55	24	5,050	2,016	2,800	700x140	8,900
PRB-12000	12,000	4,800-7,200	55	20	5,500	2,160	2,753	700x140	9,520
PRB-15000	15,000	6,000-9,000	75	20	5,900	2,170	2,910	700x140	9,950
PRB-20000	20,000	8,000-12,000	90	17	7,180	2,690	2,830	700x140	13,500
PRB-25000	25,000	10,000-15,000	110	12	7,990	2,730	3,100	700x140	17,500
PRB-30000	30,000	12,000-18,000	132	12	8,450	2,860	3,300	700x140	19,500

1. (*) (**): Changes are available according to the customer's request.
2. All specifications and illustrations are as accurate as is reasonably possible, but they are not binding.
3. PerMix reserves the right to modify the design without notice.

Gallery:



Ribbon Mixer with Pneumatic Discharging



PRB-300 Blender with Loading Manhole



12 Cubic Meters Ribbon Mixer



Ribbon Mixer with Screw Conveyor

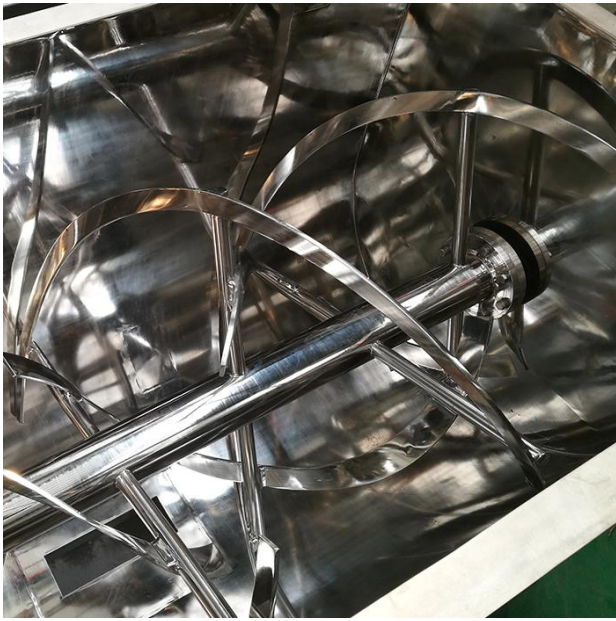

Internal View of PRB Ribbon Mixer



Ribbon Mixer with Bolted Ribbons



Vent Port with Safety Grid



Internal View of Discharging Housing